

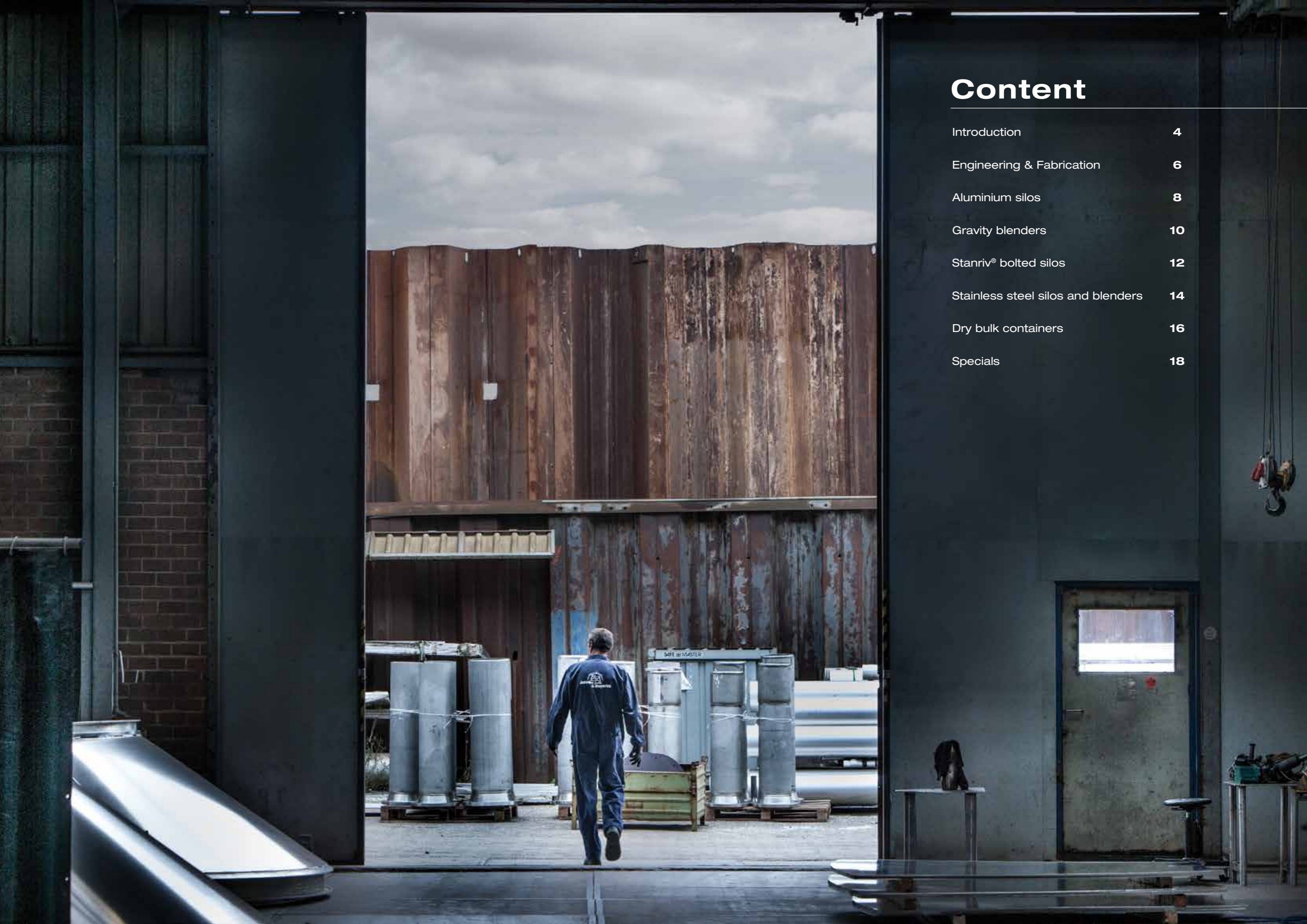

**Worldwide silo experience**

---



# Content

- Introduction 4
- Engineering & Fabrication 6
- Aluminium silos 8
- Gravity blenders 10
- Stanriv® bolted silos 12
- Stainless steel silos and blenders 14
- Dry bulk containers 16
- Specials 18



# Introduction

Founded in 1945, Jansens & Dieperink has 70 years experience in engineering, fabrication and site assembly of large aluminium and stainless steel constructions. Our services range from detailed engineering up to and including construction on site.

Our company is ISO-9001 and DIN EN ISO 3834-3 certified.

On the map you can see the locations where Jansens & Dieperink has completed projects.



# Engineering & Fabrication

Jansens & Dieperink's knowledge of silos and blender technology is unsurpassed. When designing an aluminium or stainless steel silo/blender, our engineers factor in product properties, as well as other essential parameters such as wind and earthquake loads. In our laboratory we are able to test bulk solids to determine their exact properties. Also blending tests can be performed with our test blenders.

Just as important as engineering is the quality of the manufactured product. J&D continuously invests in state of the art fabrication technologies to reduce production costs and to increase the quality of the end product. Having project references in more than 60 countries worldwide, we can guarantee optimum quality, efficiency and reliability, no matter where your project is located.



Avery test blender at J&D, Zaandam



# Aluminium silos

J&D aluminum silos with sizes up to 6,750 m<sup>3</sup> are used in numerous polymer plants around the world. Our engineers custom design the silos to your specification. With J&D panel design technology for site assembly, we are able to supply high quality, fully welded, aluminum silos and gravity blenders at low cost worldwide. Silos and blenders are pre-fabricated in our production plant in the Netherlands and shipped in 40ft sea containers.

The silos and blenders are assembled and welded at the final destination by J&D-specialists. Our unique technology combined with our experience guarantees fast and safe assembly and welding under controlled conditions. Site assembled silos offer the advantage of optimization since shipping is no longer a restriction in determining the size and quantity of the required silos and blenders.

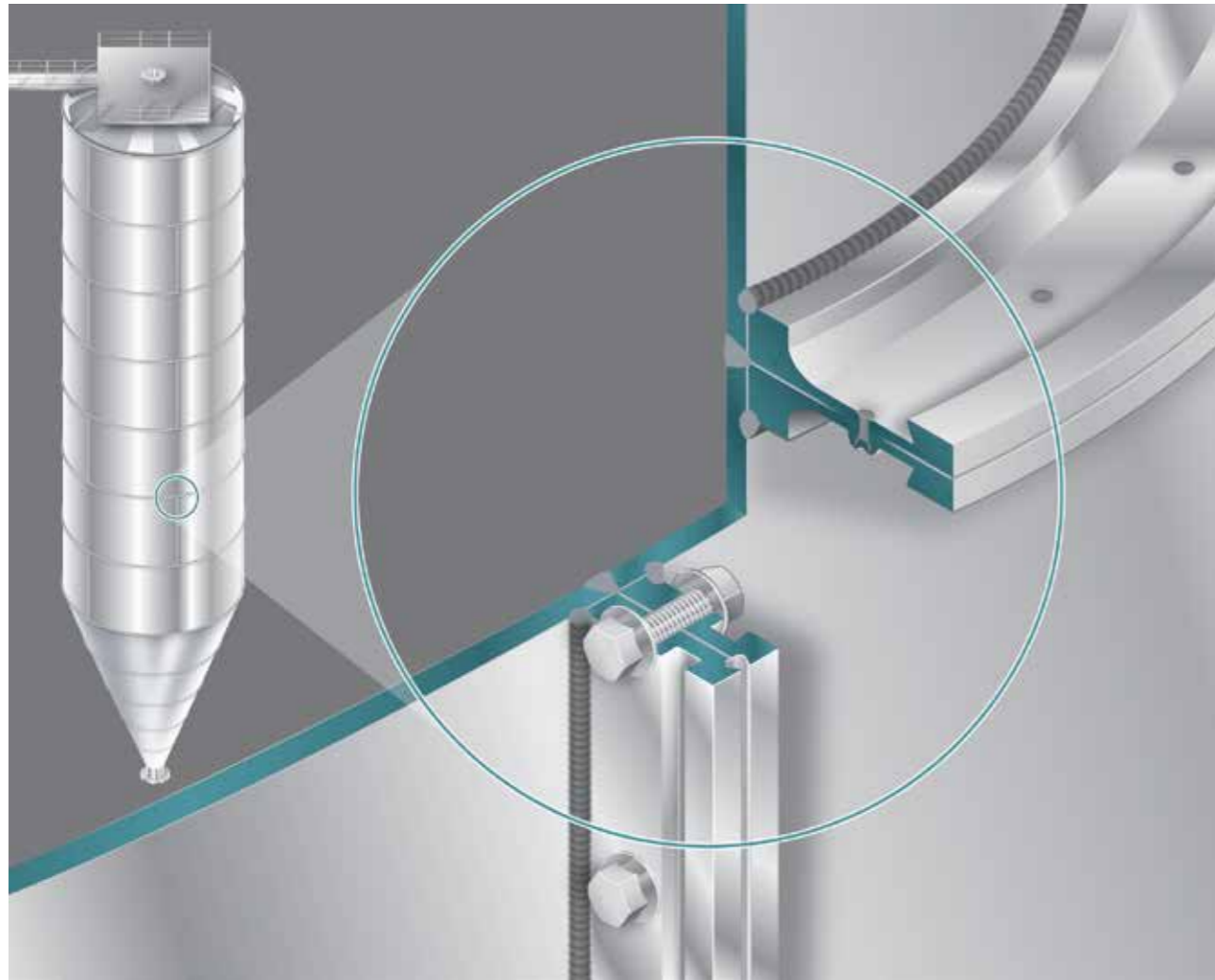

38 Silos 480 m<sup>3</sup> for TVK in Hungary



33 Silos 560 m<sup>3</sup> for Slovnaft in Slovakia (supplied via Linde)



4 PTA Silos 3,450 m<sup>3</sup> for Korteks in Turkey (supplied via Zimmer)



Typical J&D sandwich roof construction in Thailand



Typical J&D skirt/base ring for easy installation



Typical J&D pipe support clip

# Gravity blenders

Gravity blending has gained importance in the petrochemical industry, not only to ensure quality of the end product in polymer plants, but also in view of saving operational costs. We supply the best gravity blending technology available in the market. With the Avery gravity blender® you can blend large volumes (up to 2000 m<sup>3</sup>) with minimum recirculation and obtain a top quality blend. Reduction in recirculation saves you time, energy and results in a significant reduction of dust and debris which is created during recirculation.

The patented blending technology we offer today has been developed over thirty years through extensive testing and working closely with customers in polymer plants. Avery gravity blenders® are used in almost all polymer processes on the market today. Also for sticky products such as LDPE/EVA, J&D can design and manufacture gravity blenders. Avery blenders can be combined with degassing, cooling, inerting or drying. With a track record of more than a thousand gravity blenders in operation you can rely on us to be your partner for optimizing your blending requirements.

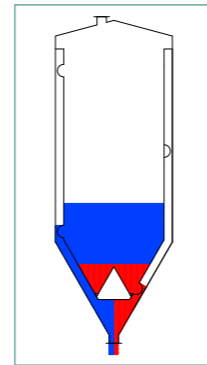
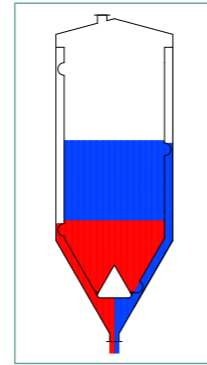
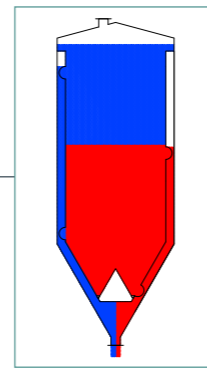

Floating top hole principle

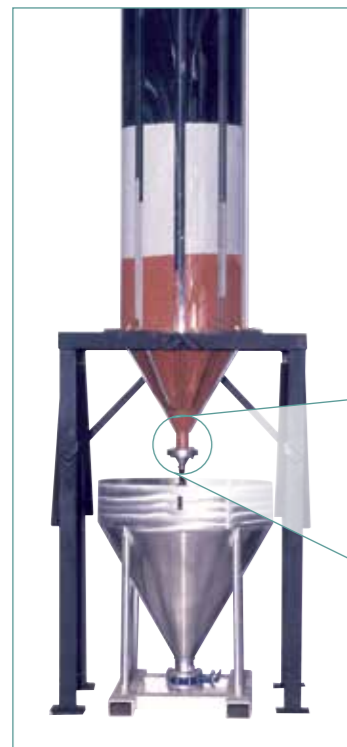

Test blender at J&D Zaandam

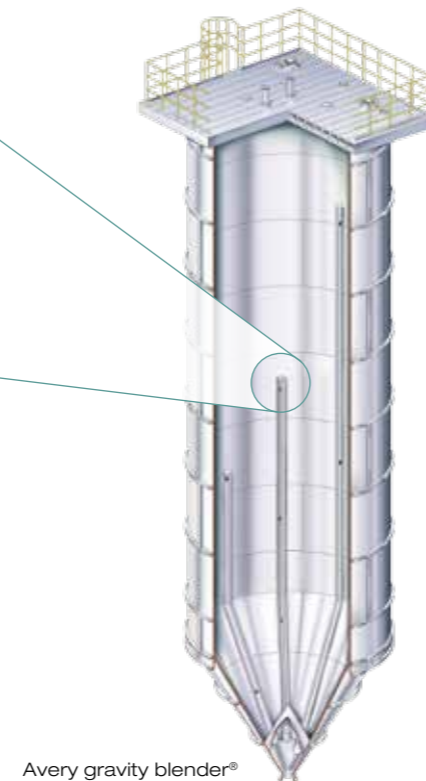
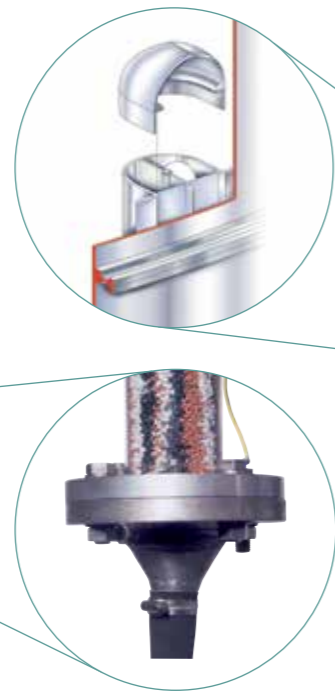

Avery gravity blender®



# Stanriv® bolted silos

The concept: Prefabricated silo parts are delivered in sea containers and simply bolted together. It is simple and easy! No welders or specialized personnel are required!

Stanriv® bolted silos offer you the full advantage of a high quality aluminium silo but eliminates the requirement for welding during site assembly. Stanriv® bolted silos are:

- Assembled using a unique patented design
- Delivered as an assembly kit in prefabricated segments
- Shipped in standard 40 ft. sea containers
- Ranging up to 500 m<sup>3</sup> (see our website for details)

Assembly of Stanriv silos is very easy and requires little time. A 200 m<sup>3</sup> silo can be erected within 4 working days. Where other suppliers apply a sealing between silos segments, J&D applies the sealing on the outside. This innovative patented technology does not require gaskets, with risk of damage/leakage. Instead a sealing is applied on the outer flange connection ensuring tightness.

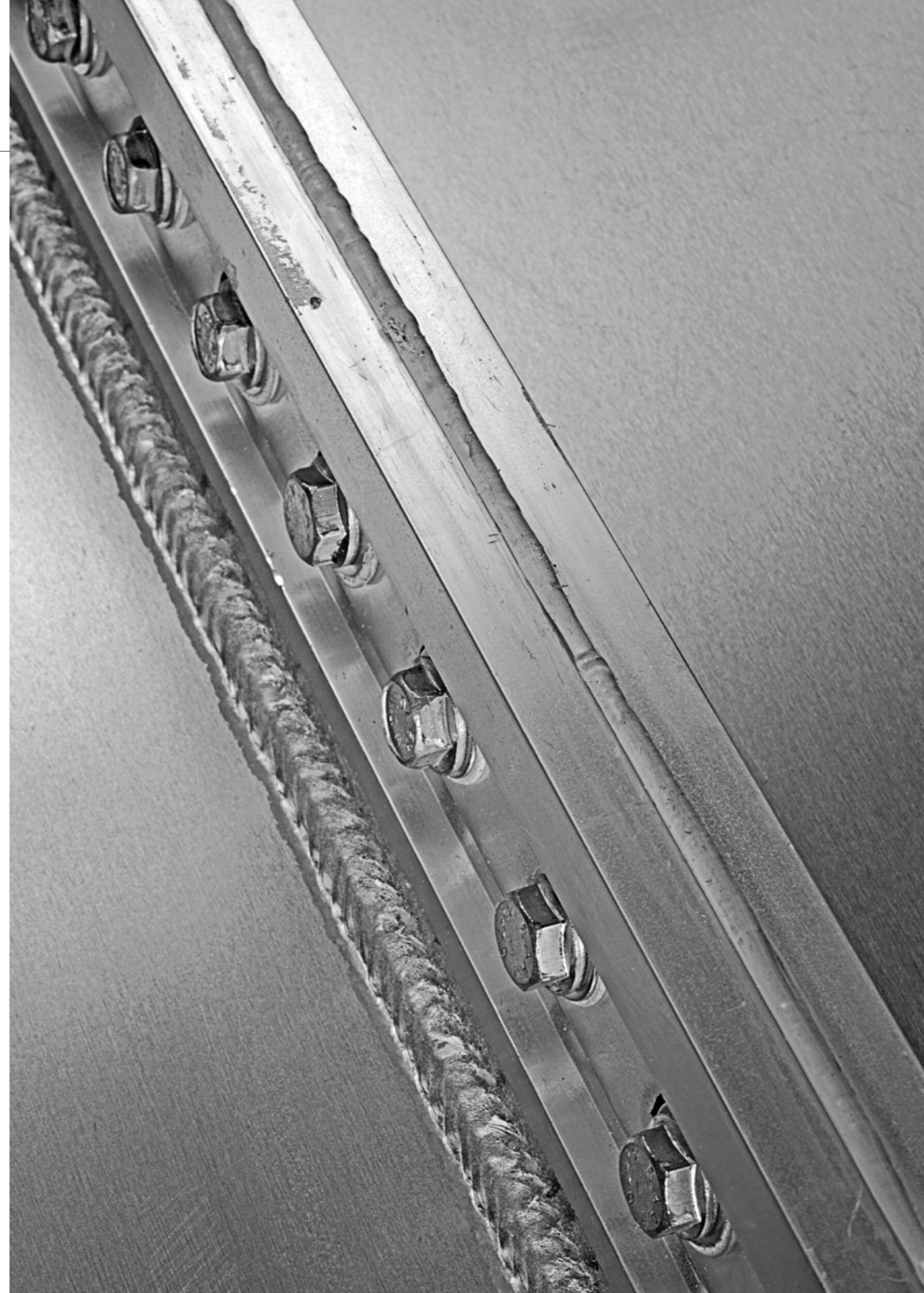
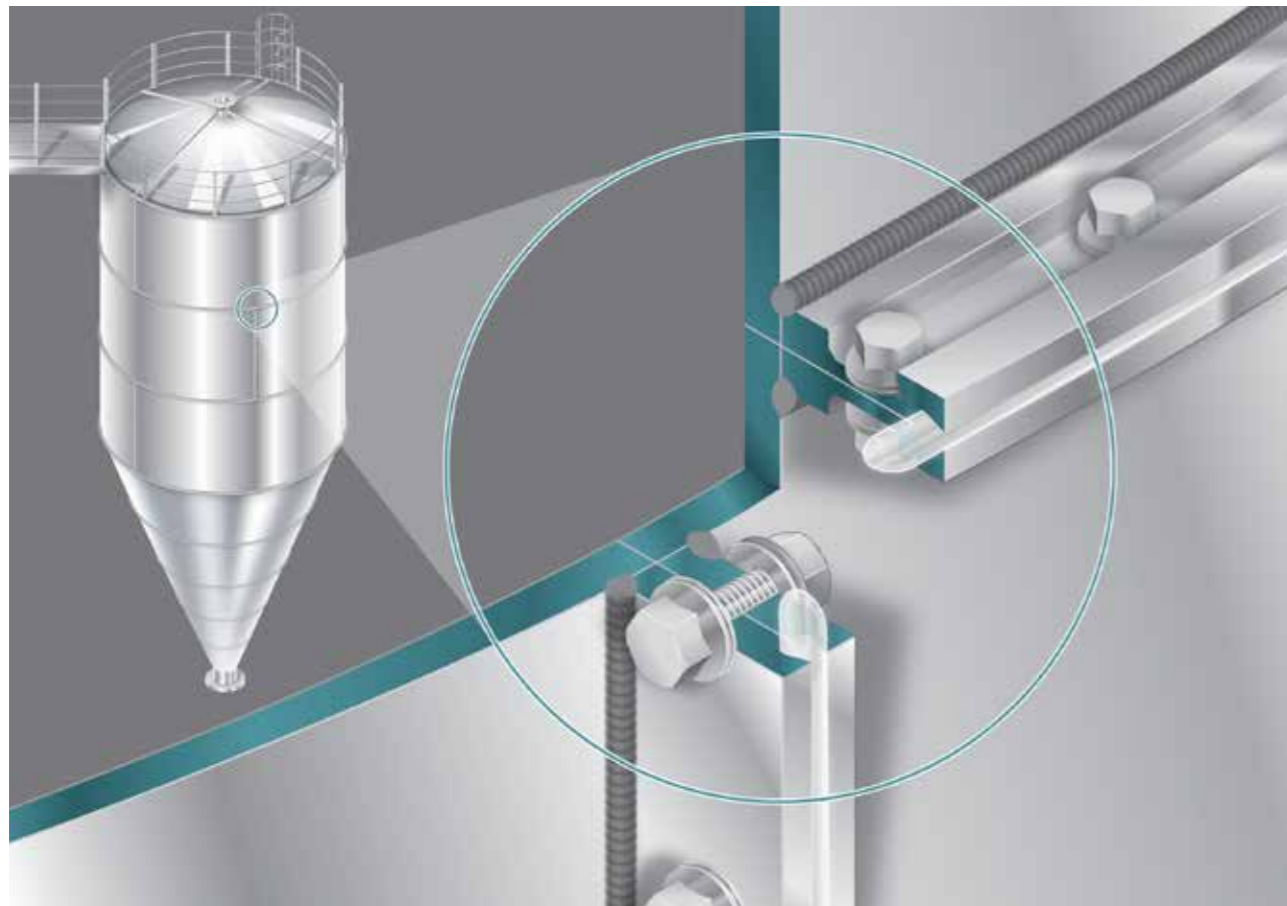

# Stainless steel silos and blenders

In case stainless steel is the preferred material of construction J&D can offer large silos and blenders up to 6000 m<sup>3</sup> including on site construction on turnkey basis. We apply the same prefab technology as for aluminium which results in:

- Low prefabrication cost in our highly automated manufacturing plant
- Low shipping cost in 40 ft. sea containers
- Low site assembly costs

Our panel design stainless steel silos are assembled on site by a highly skilled and experienced team of J&D professionals using state of the art automated welding equipment and in-house designed tools for fast assembly.

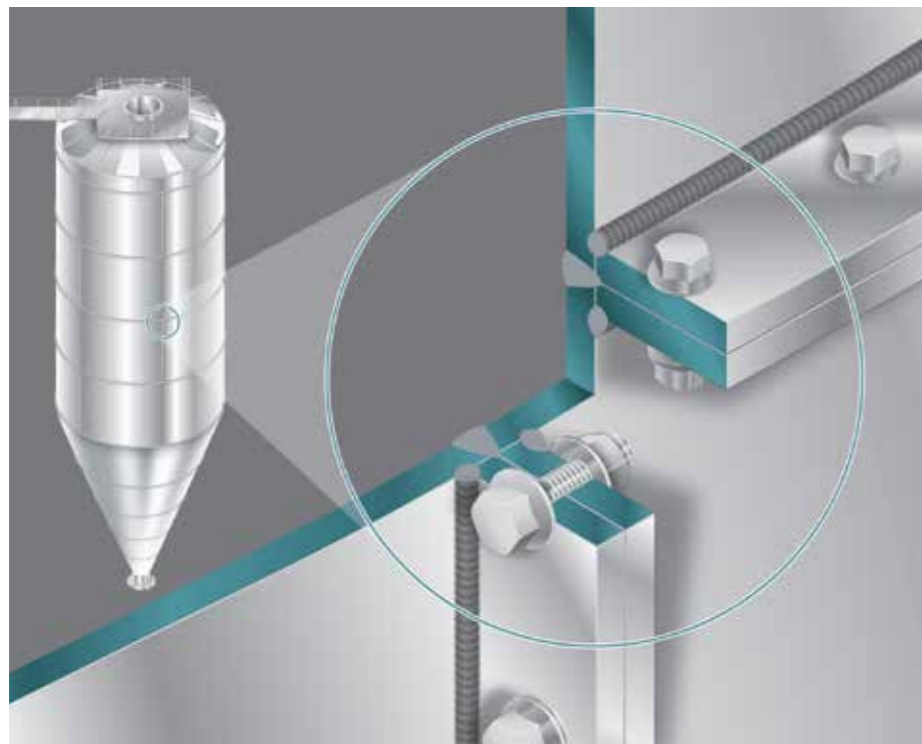

Stainless steel flange connection



3 PTA 3.300 m<sup>3</sup> silos for Reliance in India



Virgin powder silo 656 m<sup>3</sup> for BP/Secco in China

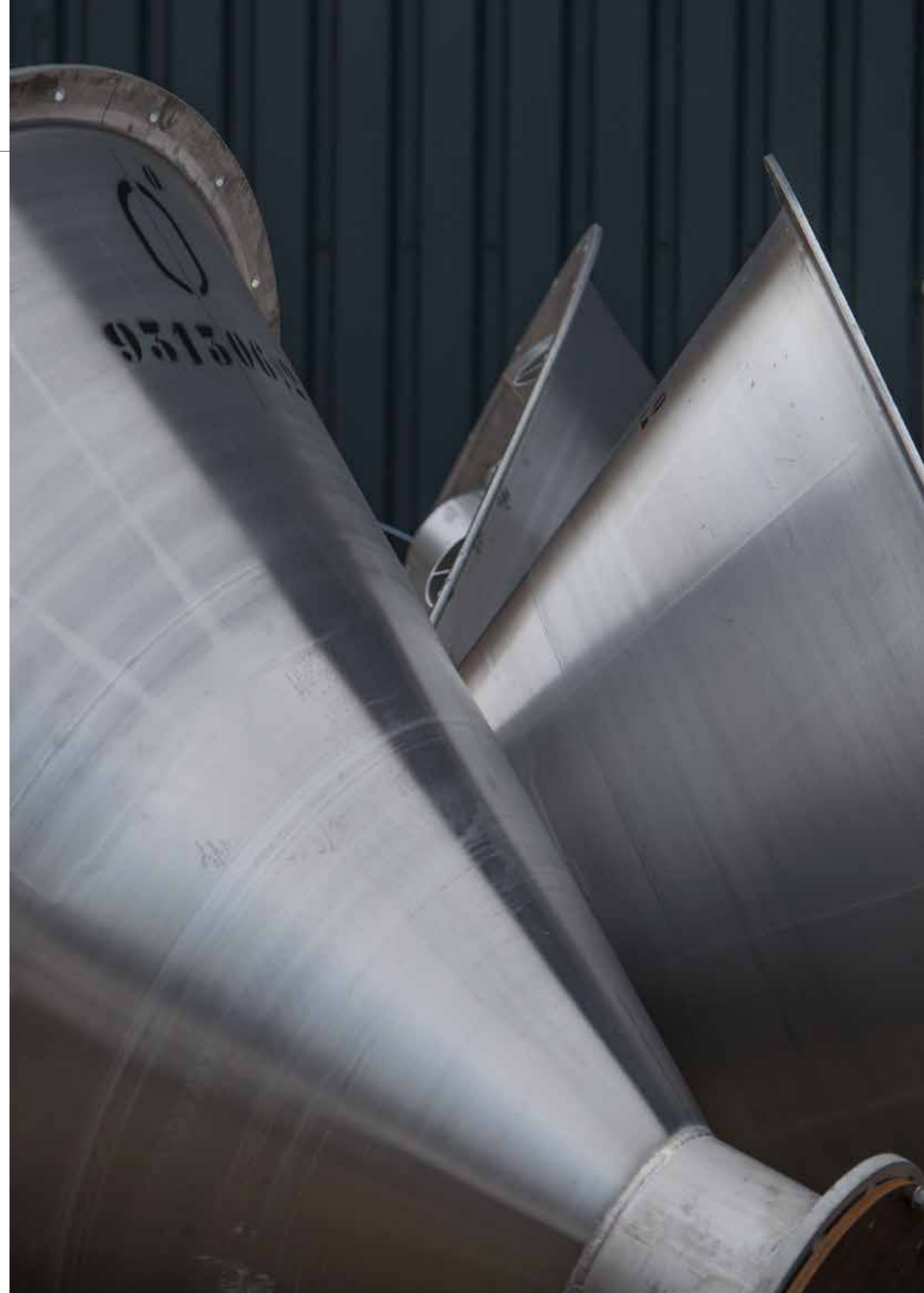



# Dry bulk containers

The Jansens and Dieperink bulk container is a clever concept for dry-bulk transport in containers. This unique container combines the strength of a carbon steel container with a clean aluminium or stainless steel innerliner for storage of high-quality dry bulk products. The J&D bulk container comes in 20, 30 and 40 foot lengths.

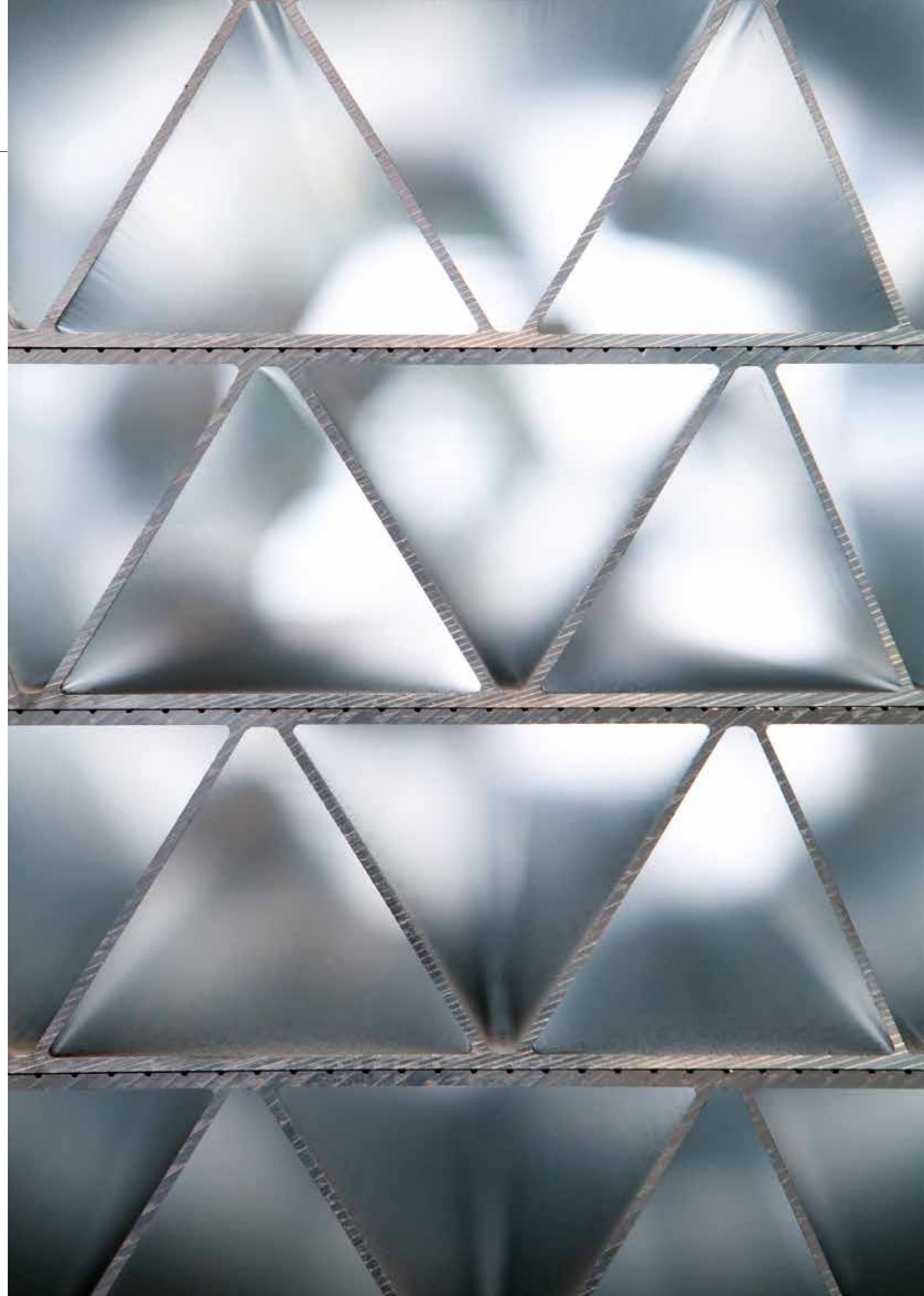
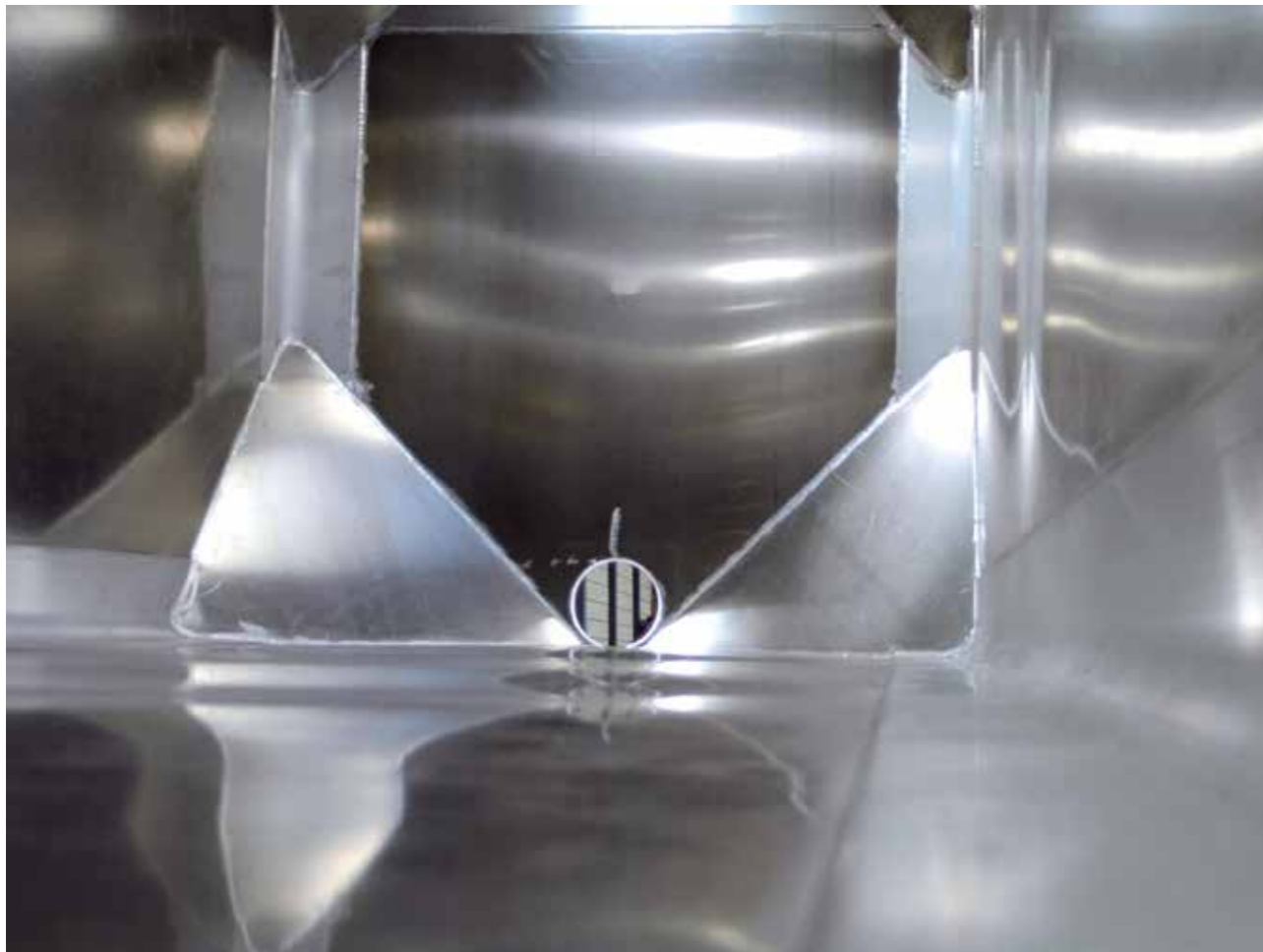
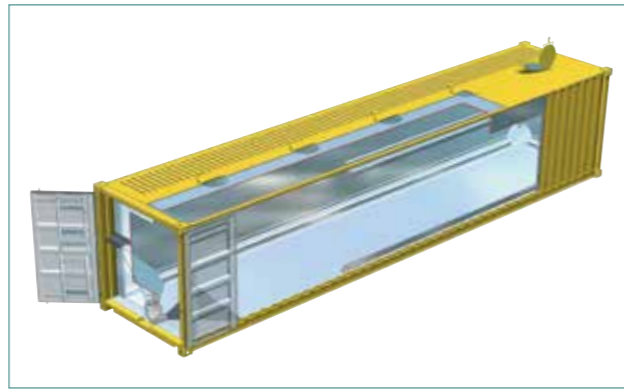

# Specials

Our sophisticated equipment for manufacturing aluminium and stainless products, combined with our engineering expertise enables us to construct high quality, special products.



Duplex desorber 940 m<sup>3</sup>

Fluidization bottom Ø 6500 mm



BPA prilling tower





Zuidijk 416, 1505 HE Zaandam  
P.O. Box 436, 1500 EK Zaandam  
The Netherlands

Phone +31(0)75 616 85 55  
Fax +31(0)75 616 85 69  
E-mail [info@jansensanddieperink.com](mailto:info@jansensanddieperink.com)  
[www.jansensanddieperink.com](http://www.jansensanddieperink.com)